

LLE-1550-D

High Performance Microwave Coax Cable

Product Description

Superlink LLE series is a cost-effective low loss cable. Compared to traditional foam PE cables, LLE cables offer higher operation temperature range, lower loss and better RF shielding effectiveness. These features make LLE cable the best choice for wireless application like GPS, Cellular and satellite.

Feature & Benefit

- 84%Vp LD PTFE+AL Foil
- Low loss

Product Structure

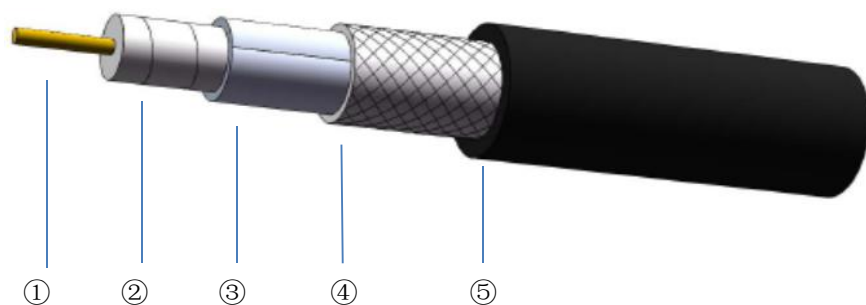

	①Center Conductor	②Dielectric	③Outer Conductor	④Outer shield	⑤Jacket
Material	Copper	LD PTFE	Copper-foil	SPC	FEP
Size (mm)	5.20±0.05	13.89±0.05	13.99±0.07	14.70±0.20	15.50±0.20

Specifications

Impedance	50Ω
Operation Frequency	6GHz
Velocity of Propagation	84%
Shielding Effectiveness	90dB
Voltage Withstand	5000V,DC
Bend Radius:repeated	150mm
Bend Radius:installation	60mm
Weight	450g/m
Temp, Operating&Installation	-55~155°C
Temp,Storage	-65~155°C

Attenuation (Typical@25°C VSWR=1.0)

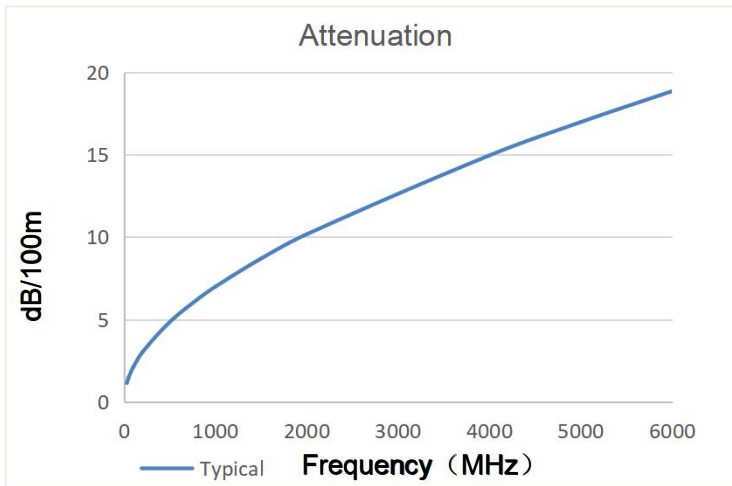

Frequency(MHz)	Attenuation (dB/100m)
30	1.1
50	1.5
80	1.9
100	2.1
200	3.0
500	4.8
800	6.2
1000	7.0
1500	8.7
2000	10.2
4000	15.0
5000	17.0
6000	18.9

$$K1= 0.205702$$

$$K2= 0.000488$$

$$\text{Attenuation}=K1* \sqrt{F}+K2*F$$

Power (40°C VSWR=1.0 Sea Level)

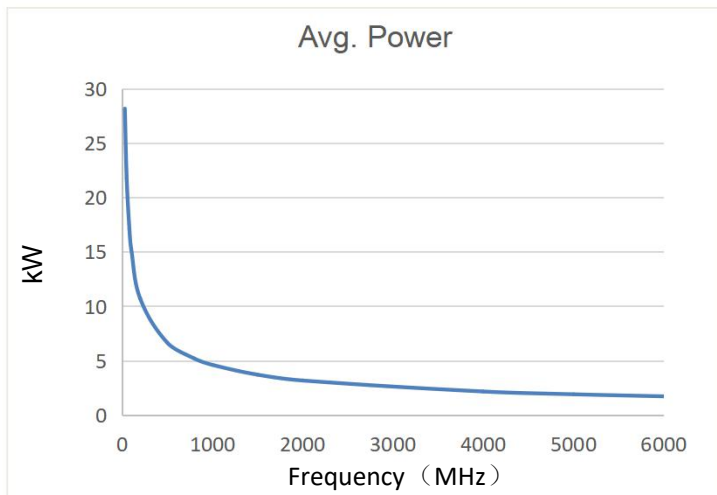

Frequency(MHz)	Avg.Power (kW)
30	28.178
50	21.745
80	17.117
100	15.272
200	10.696
500	6.640
800	5.180
1000	4.599
1500	3.697
2000	3.161
4000	2.150
5000	1.894
6000	1.705

Ver A-1